

Thermopile sensor unit

TSUP-A1D16B-AU-50-120

- Applications Microwave oven
(Food temperature detection)
Target temperature -20~120°C

- Feature Thermopile sensor Unit (SMBus comms)
4 x 4 square element

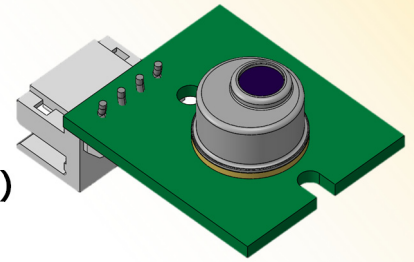

Dimensions

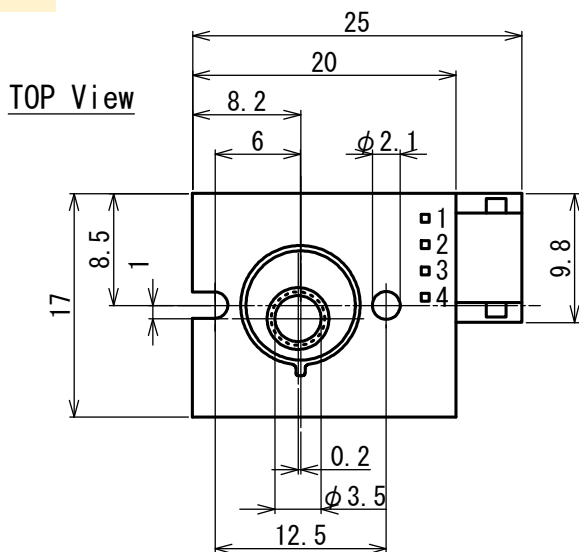

SIDE View

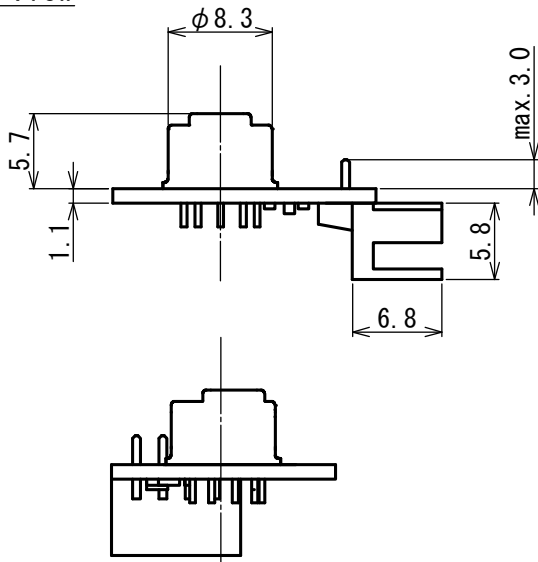

Tolerance with no specified : +/- 0.2

FOV

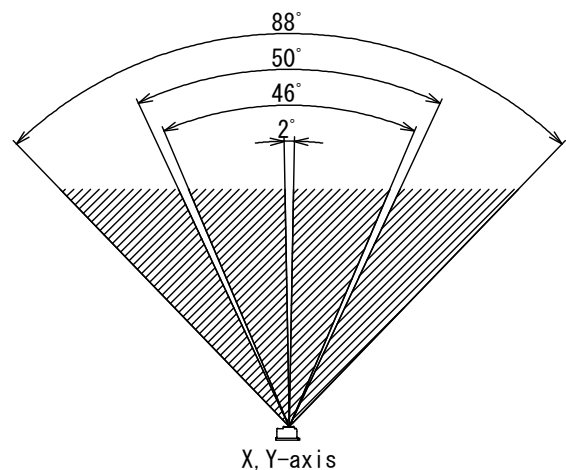

Circuit diagram

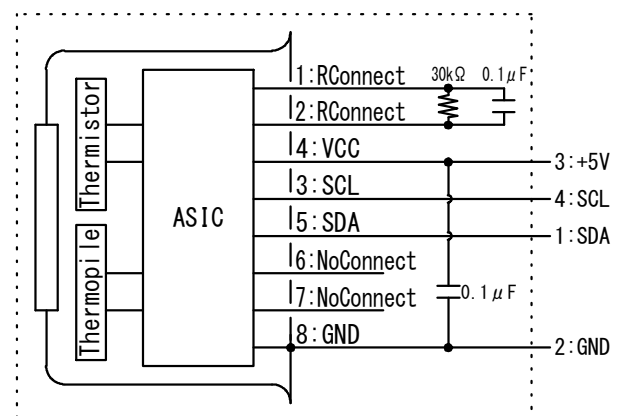

■ Main Parameter

Parameter	Condition	Spec.			Unit
		Min.	Typ.	Max.	
Operating Voltage		4.5	5	5.5	V
Detection Temperature		-20		120	°C
Operating Temperature		-20		100	°C
Storage Temperature		-30		105	°C
Accuracy	Tobj=70°C、Tamb=25°C	-2		+2	°C
Time Constant				200	msec.