

Thermopile sensor

A3D01S-CU-50-300

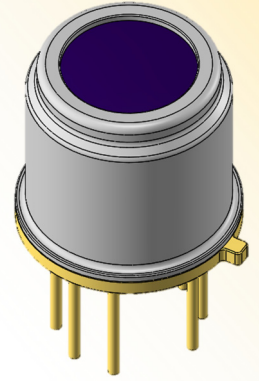

TO-5

■ Applications **Printer**
(Thermal roller temperature detection)

■ Feature **ASIC built-in thermopile (SMBus comms)**
Focused detection (Single element)

Dimensions

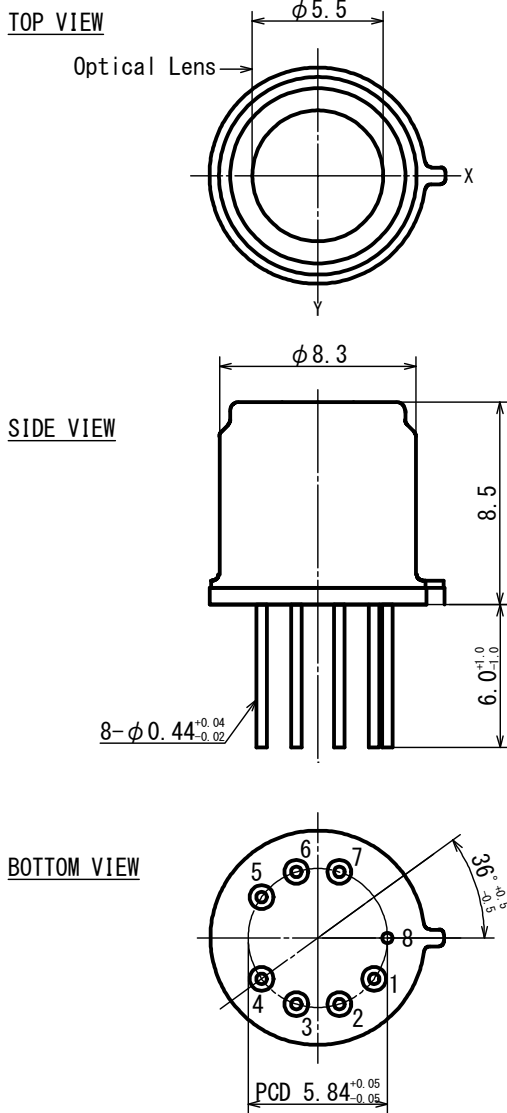

Tolerance with no specified : +/- 0.2

FOV

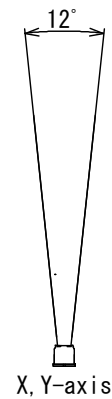

Circuit diagram

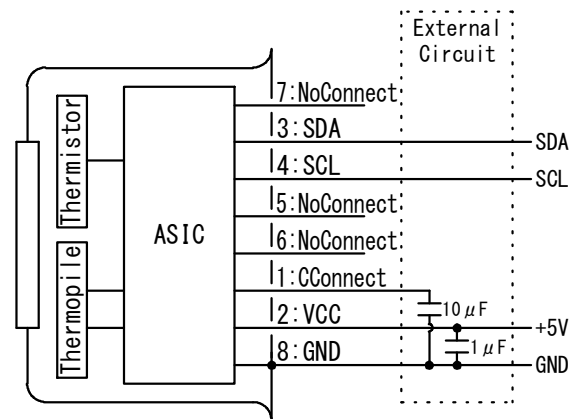

■ Main Parameter

Parameter	Condition	Spec.			Unit
		Min.	Typ.	Max.	
Operating Voltage		4.5	5	5.5	V
Detection Temperature		-20		400	°C
Operating Temperature		-20		100	°C
Storage Temperature		-30		105	°C
Accuracy	Tobj=200°C, Tamb=25°C	-3		+3	°C
Time Constant				200	msec.