

SH188 Ultra-high Sensitivity Hall Effect Latch

SH188 is an ultra-high sensitivity Hall-effect latch designed in advanced DMOS technology. The following are integrated on a single silicon chip: voltage regulator, reverse bias protection, ESD protection, Hall voltage generator, chopper stabilized small-signal amplifier, Schmitt trigger, and open-drain output. Superior high-temperature performance is made possible through a dynamic offset cancellation that utilizes chopper-stabilization.

Features

- Ultra-high sensitivity (1.5mT typ.)
- Stable temperature characteristics
- Good ESD protection (HBM4kV min.)
- Reverse bias protection on power supply pin

Typical Applications

- High temperature fan motor
- 3 phase BLDC motor
- Speed sensing
- Position sensing
- Current sensing
- Revolution counting

Order Information

Order No.	Part No.	Temperature	Package	—	Packing
SH188KUA	SH188	K	UA		
SH188KSO-TR	SH188	K	SO	—	TR

Legend:

Temperature Code: K (-40°C ~ 125°C)

Package Code: UA (TO92S), SO (SOT23)

Packing Code: Brank (Balk, 500pcs/Bag), TR (Tape & Reel, 3,000pcs/Reel)

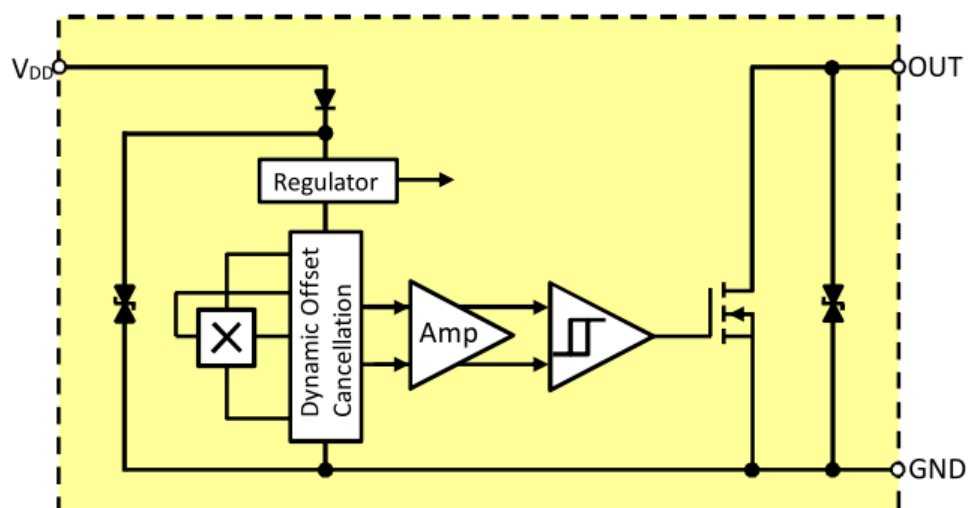
Function Block Diagram

Absolute Maximum Ratings ($T_A=25^{\circ}\text{C}$)

Parameter	Symbol	Value		Unit
		Min	Max	
Supply Voltage	V_{DD}	-28	28	V
Output Voltage	V_{OUT}	-0.3	28	V
Output Current	I_{SINK}	-	50	mA
Operating Temperature Range (K)	T_A	-40	125	$^{\circ}\text{C}$
Storage Temperature Range	T_S	-65	150	$^{\circ}\text{C}$
Maximum Junction Temperature	T_J		150	$^{\circ}\text{C}$
Power Dissipation (UA/SO)	P_D		606/230	mW

Electrical Characteristics ($T_A=25^{\circ}\text{C}$, $V_{DD}=12\text{V}$)

Parameter	Test Condition	Symbol	Value			Unit
			Min	Typ	Max	
Supply Voltage		V_{CC}	2.5	-	24	V
Consumption Current	$V_{OUT}=\text{High}$	I_{DD}	-	-	5	mA
Output Saturation Voltage	$I_{SINK}=20\text{mA}$, $V_{OUT}=\text{Low}$	V_{SAT}	-	-	0.4	V
Output Leakage Current	$V_{OUT}=\text{High}$ (12V)	I_{LEAK}	-	-	10	μA
Output Rise time	$R_L=1.1\text{k}\Omega$, $C_L=20\text{pF}$	t_R	-	0.04	0.45	μs
Output Fall time	$R_L=820\Omega$, $C_L=20\text{pF}$	t_F	-	0.18	0.45	μs
Electro-Static Discharge	HBM		4	-	-	kV

UA-package Magnetic Characteristics ($T_A=25^\circ\text{C}$, $V_{DD}=12\text{V}$)

Parameter	Test Condition	Symbol	Value			Unit
			Min	Typ	Max	
Operate Point	S pole to branded side	B_{OP}	0.5	-	2.5	mT
Release Point	N pole to branded side	B_{RP}	-2.5	-	-0.5	mT
Hysteresis		B_{HYS}	-	3	-	mT

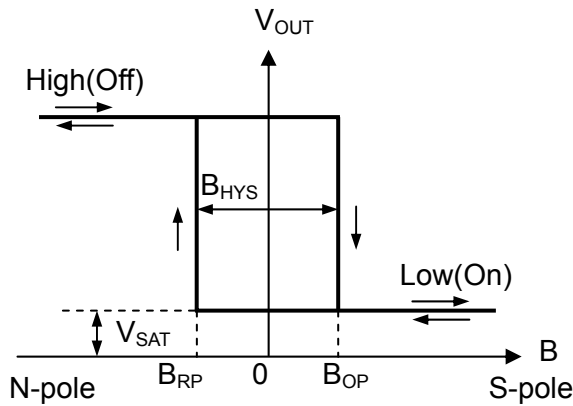
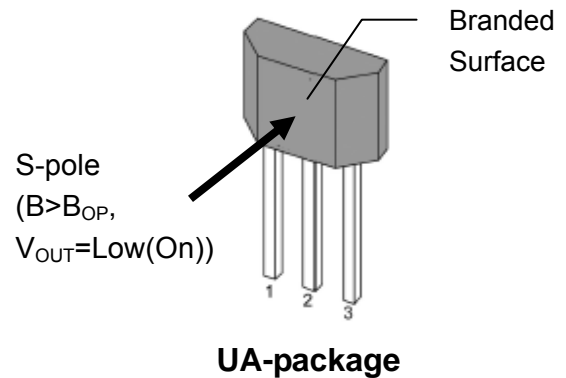
Switching Characteristics

UA-package
SO-package Magnetic Characteristics ($T_A=25^\circ\text{C}$, $V_{DD}=12\text{V}$)

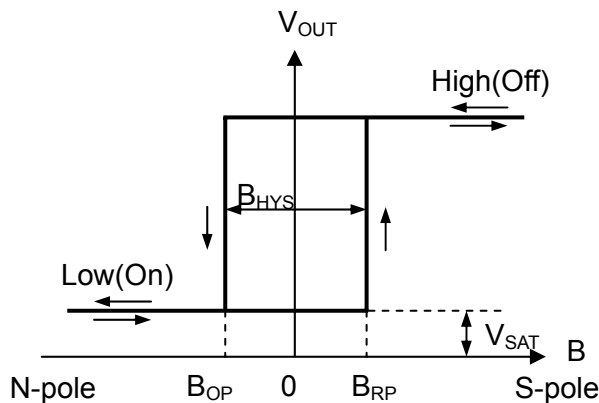
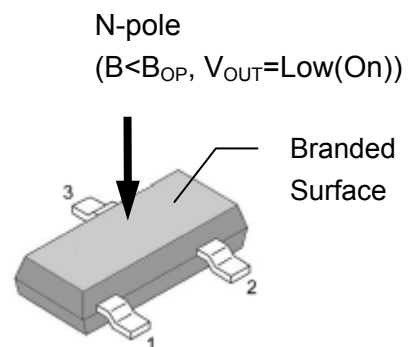
Parameter	Test Condition	Symbol	Value			Unit
			Min	Typ	Max	
Operate Point	N pole to branded side	B_{OP}	-2.5	-	-0.5	mT
Release Point	S pole to branded side	B_{RP}	0.5	-	2.5	mT
Hysteresis		B_{HYS}	-	3	-	mT

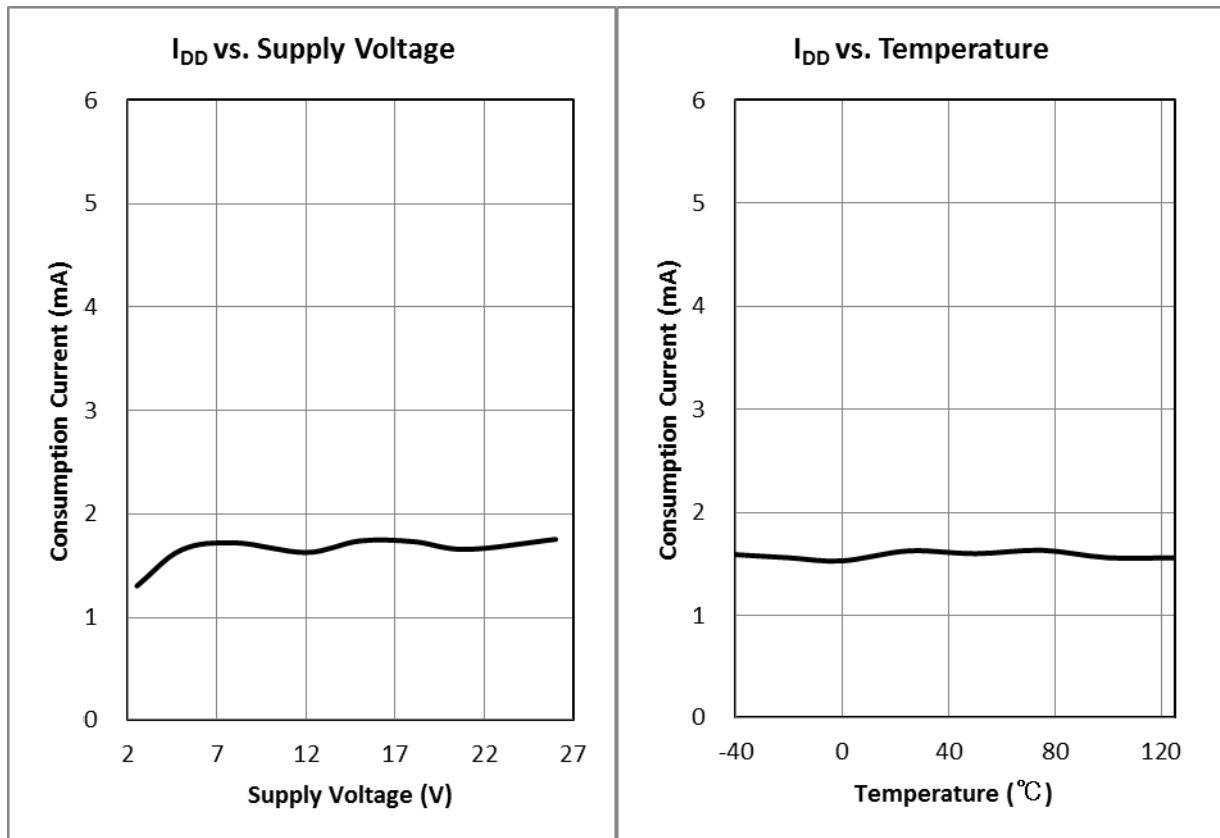
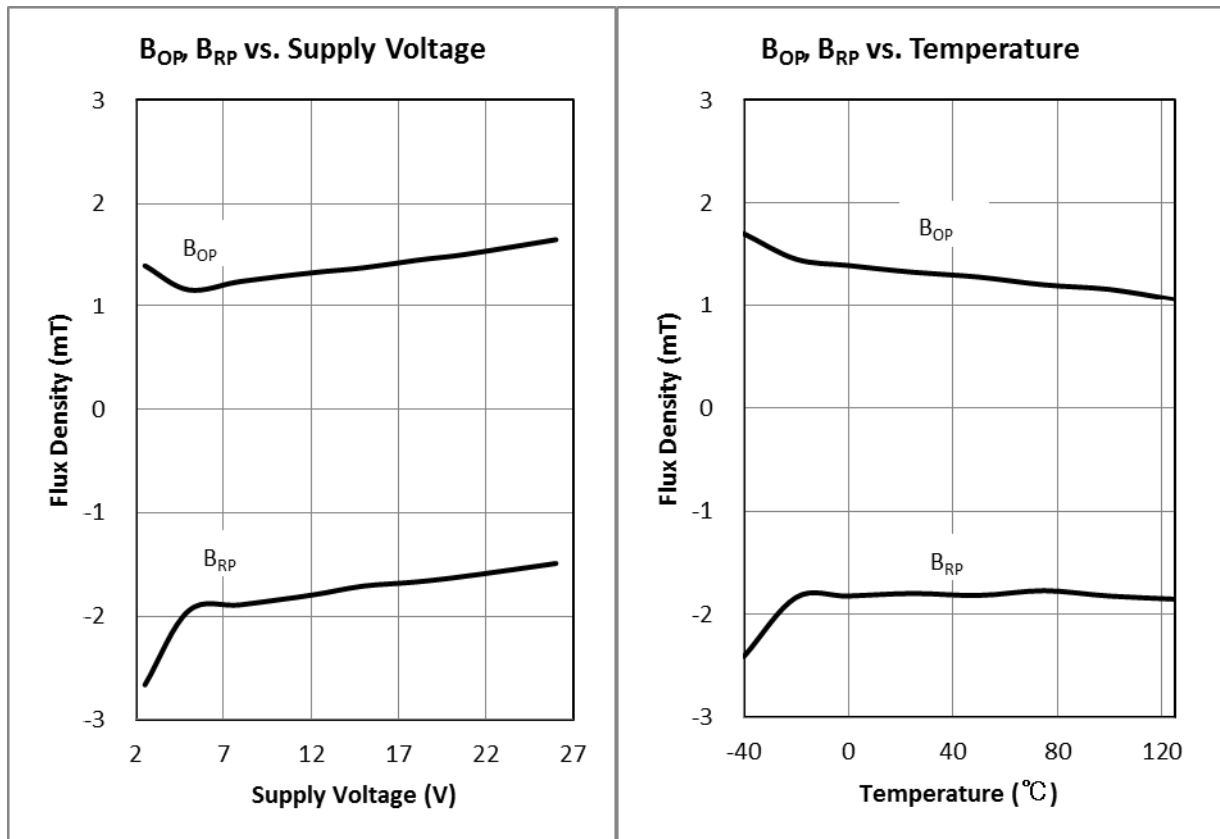

Switching Characteristics

SO-package

Performance Graphs

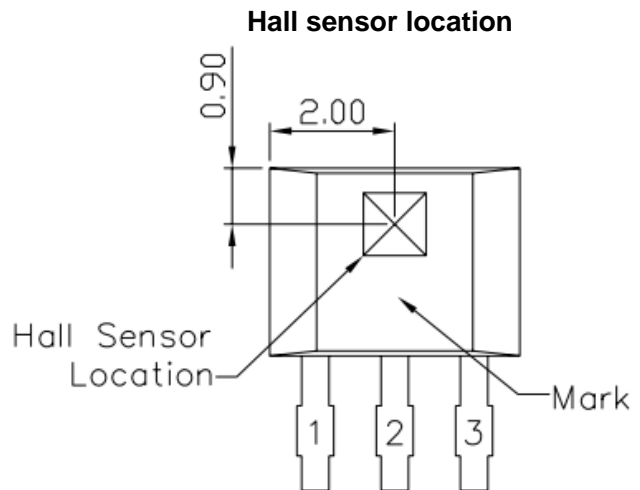
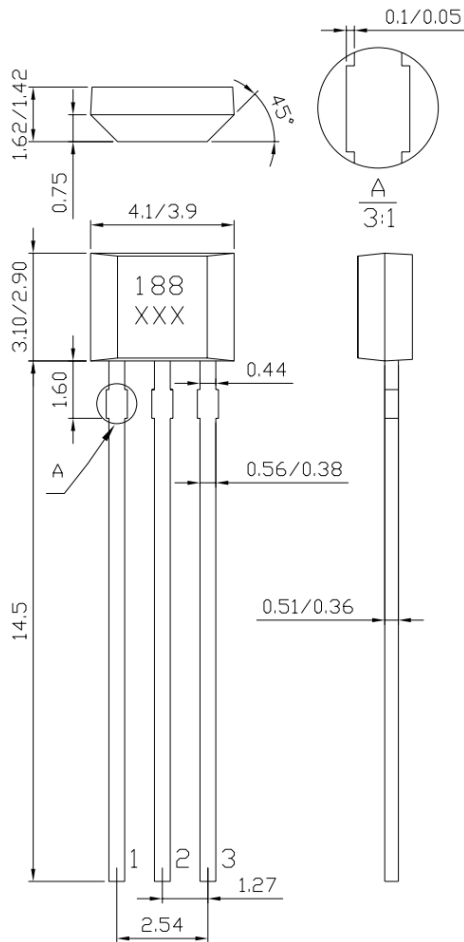

Sensor Location, Package Dimension and Marking

UA-package: T092S



NOTES:

1. Controlling dimension: mm;
2. Leads must be free of flash and plating voids.
3. Do not bend leads within 1 mm of lead to package interface.
4. PINOUT:
Pin 1 V_{DD}
Pin 2 GND
Pin 3 Output

**SO-package: SOT23
(Upper View)**

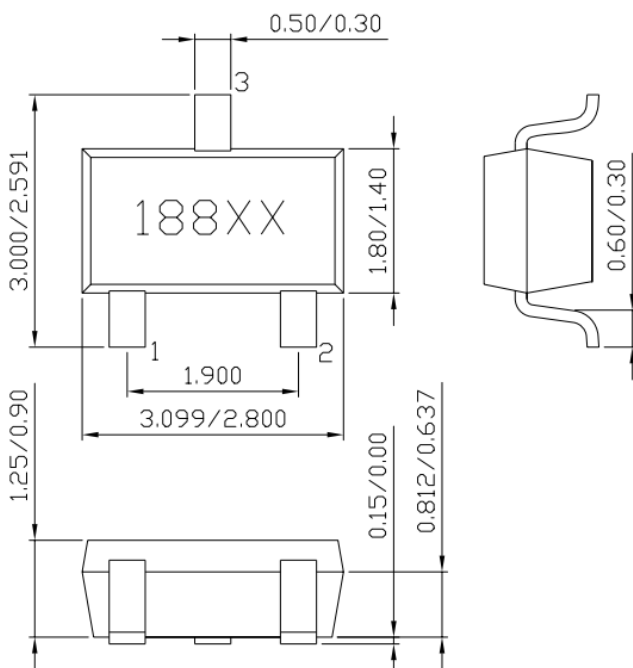

**Hall sensor location
(Bottom View)**

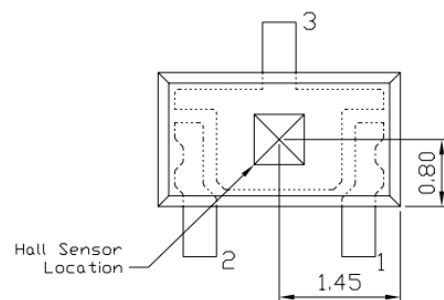

NOTES:

1. PINOUT:
Pin 1 V_{DD}
Pin 2 Output
Pin 3 GND
2. Controlling dimension: mm;
3. Lead thickness after solder plating will be 0.254mm maximum.