

MODEL

NHE524TU

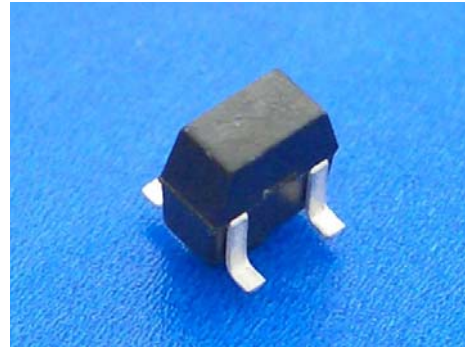

Features

- This is a high sensitivity type of Nicera Hall element using evaporated InSb film.
- It performs effectively in low magnetic fields due to the high sensitivity.
- The input and output resistance values are suitable for transistor circuits.

Applications

- Brushless motors
- DVD drive, CD-ROM drive, floppy disk drive
- Other small precision motors
- Non-contacting magnetic sensors
- Position sensors, rotation sensors, current sensors
- Magnetic flux sensors other than those above

Specification

◆ Halogen and Pb-free products ◆

Nicera is able to supply halogen and Pb-free products.

For these products, "HF" is put at the end of model names as below,

NHE524TU-HF

◆ Dimensional Drawing ◆

(UNIT: mm)

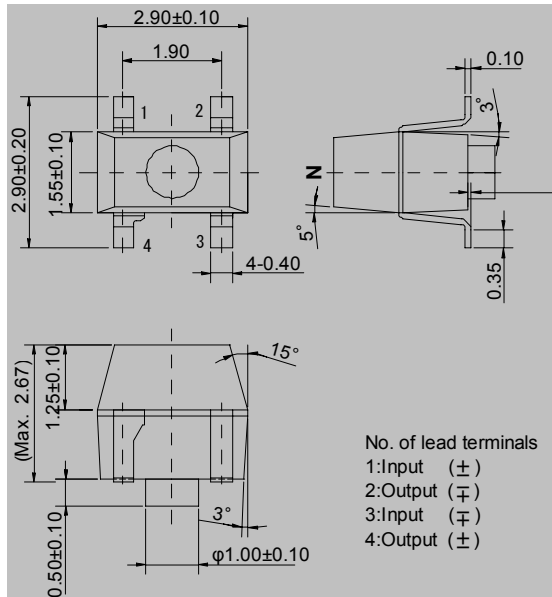

◆ Absolute Maximum Ratings ◆

Item	Symbol	Limit	Unit
Max. Input Current	I _{max}	20(at 25°C)	mA
Operating Temp. Range	T _{opr}	-40~110	°C
Storage Temp. Range	T _{stg}	-40~125	°C

◆ Electrical Characteristics (T=25°C) ◆

Item	Symbol	Conditions	Min.	Typ.	Max.	Unit
Output Voltage	V _H	V _c =1V B=50mT	196		370	mV
Offset Voltage	V _o	V _c =1V B=0mT	-7		7	mV
Input Resistance	R _{in}	I=1mA	240		550	Ω
Output Resistance	R _{out}	I=1mA	240		550	Ω
Temp. Coefficient of V _H	※1 α _{HI}	Standard 20°C Average 0~40°C B=50mT I _c =5mA		-1.8		%/°C
Temp. Coefficient of R _{in}	※2 α _R	B=0mT I _c =0.1mA		-1.8		%/°C

※1: $\alpha_{HI} = [1/V_H(T1)] \times [(V_H(T3) - V_H(T2)) / (T3 - T2)] \times 100$

※2: $\alpha_R = [1/R_{in}(T1)] \times [(R_{in}(T3) - R_{in}(T2)) / (T3 - T2)] \times 100$

T1=20°C, T2=0°C, T3=40°C

◆ Classification of Output Voltage ◆

Model	Rank	V _H (mV)	Conditions
NHE524TU	5	196~235	Constant Voltage Drive V _H =V _H M-V _o V _H M=Measured Hall Voltage (at 50mT) V _o =Offset Voltage(at 0 mT)
	6	225~275	
	7	265~320	
	8	310~370	

※ Please design with multiple ranks (three ranks or more).

◆ Packaging ◆

Model	Packaging	Reel Max. (pcs)	Carton Max. (pcs)
NHE524TU	Taping reel	2,500	62,500

◆ Characteristics Curve ◆

