

Thermopile sensor

TS-S2NAB-2R

■ Applications Non-contact thermometer

■ Feature Object-Sensor temperature detection (2-channel)
Wide-angle detection(Single element)

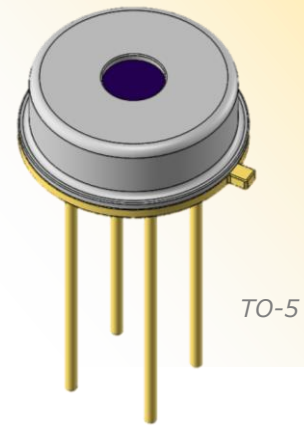

Dimensions

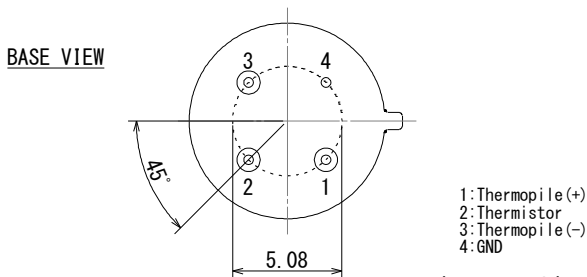
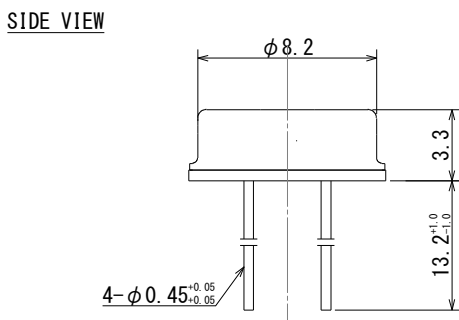
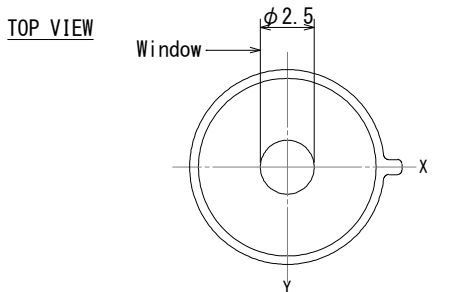

Tolerance without instruction : +/- 0.2

FOV

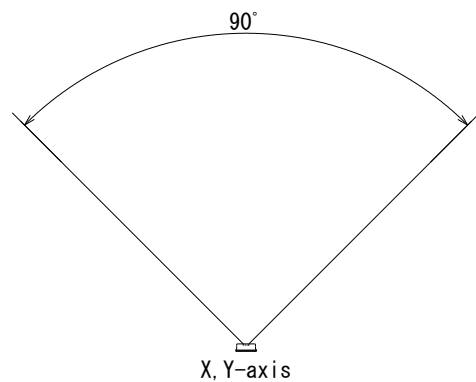

Circuit diagram

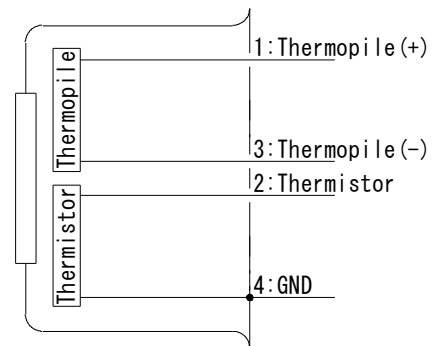

■ Main Parameters

Parameters	Condition	Spec.			Units
		Min.	Typ.	Max.	
Sensitivety Output	323K at shutter opening	1.5	2	2.5	mV
Resistance of thermopile		145	175	205	kΩ
Thermistor resistor		95	100	105	kΩ
Operating Temperature		-30		80	°C
Time Constant		25	50	80	msec.